

NOTE: IF LAST REBAR ENDS UP WITHIN LAST 1 FT OF PIPE THEN SPACING FROM CENTER POINT OF PIPE IS OK, IF NOT SPACING MUST START 1 FT LEFT OR RIGHT OF CENTER POINT

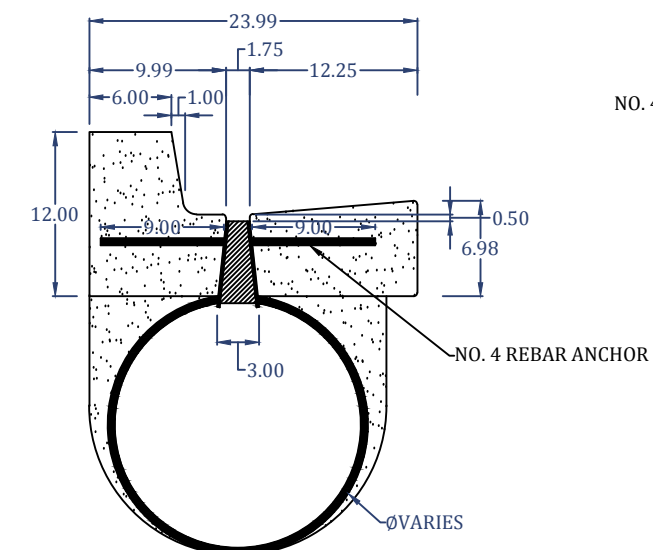

FRONT VIEW

NOTE: METHOD OF CONSTRUCTION PER CONTRACTOR

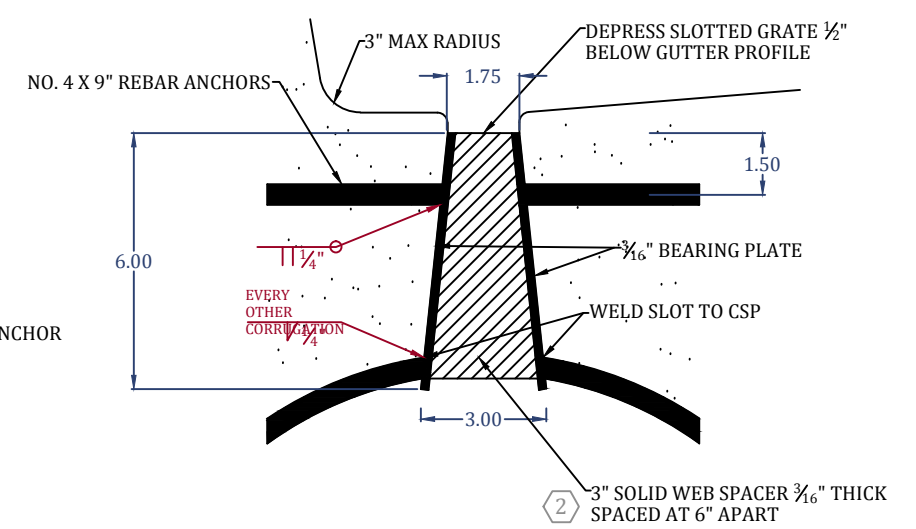

TRAPEZOID DRAIN DETAIL

NOTE: WHEN NOTCHING PIPE FOR SLOTTED DRAIN FORMS, DO NOT CUT LOCKSEAM, LAY GRATE OVER PIPE AND MARK OUT LOCKSEAM SPOTS, NOTCH GRATE AT MARKS, TACK WELD GRATE TO LOCKSEAMS.

NOTE: DOT SPECS ALLOW FOR 1/2" VERTICAL DEFLECTION AND 5/8" HORIZONTAL DEFLECTION, FC ALLOWS FOR ONLY 1/4" VERTICAL DEFLECTION AND 1/4" HORIZONTAL DEFLECTION

NO.	QTY.	PART NO.	DESC.	MATERIAL
8	1	MG0_EC	END CAP	ØVAR." x 1/4" PLATE ASTM A36
<b>END CAP</b>				
7	1	NUT.5FL	NUT	1/2" UNC FLANGE NUT
6	1	BOLT08	BOLT	1/2" x 8" UNC CARRIAGE BOLT
5	1	VARIES	MODIFIED BAND	12" WIDE MODIFIED BAND
<b>BAND</b>				
4	1	VARIES	ELBOW	ØVAR." x 3' VARIOUS RIVETED PIPE
<b>ELBOW</b>				
3	-	REBAR4	REBAR	NO. 4 REBAR (9IN REBAR/1LF PIPE)
2	-	MG006SDF	SLOTTED DRAIN FORM	RECTANGULAR DRAIN FORM (1FT FORM/1FT PIPE)
1	1	VARIES	PIPE	ØVAR." x VAR' VARIOUS CSP
<b>PIPE</b>				

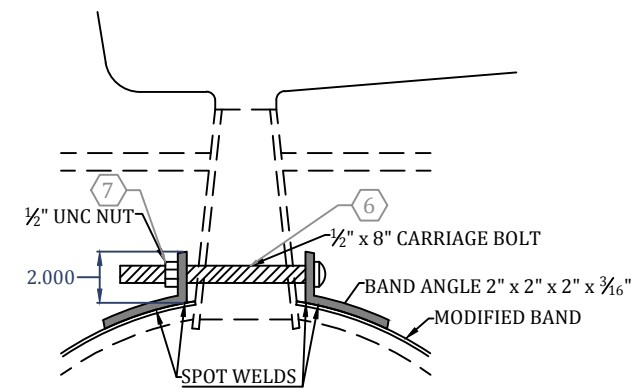

BAND ANGLE DETAIL

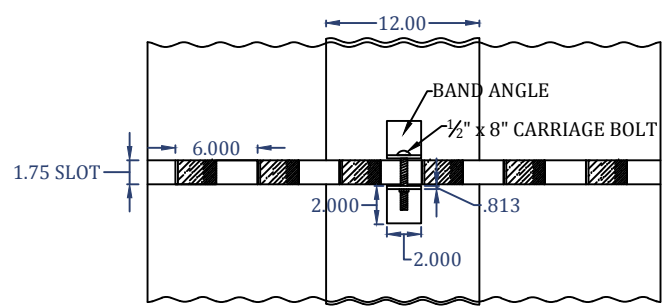

TOP VIEW

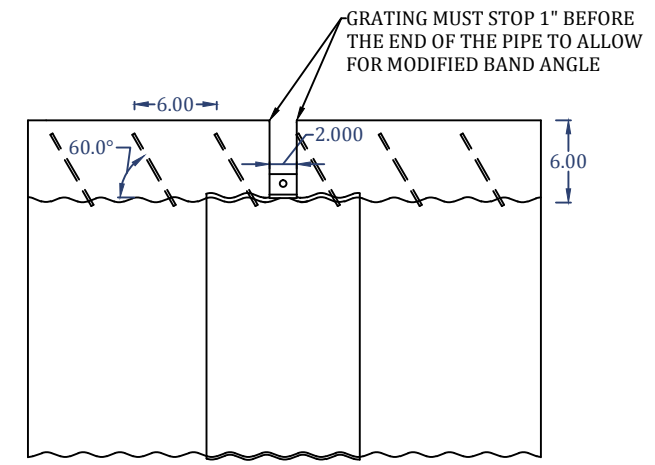

SIDE VIEW

MODIFIED COUPLING BAND DETAIL

NO.	REVISION	DATE
3	REVISED LAYOUT ECN-157	01-26-12
2	INITIAL RELEASE ECN-051	06-10-11
1	RELEASED FOR APPROVAL	06-10-11

TOLERANCES
X.X ± 0.5"
X.XX ± 0.25"
X.XXX ± 0.13"

DESCRIPTION: SLOTTED DRAIN PIPE AND BAND
DRAWN BY: C. HOMAN
DATE: JUNE 10, 2011
SHEET NO: 1 OF 1

THIS DESIGN IS PROPERTY OF TRUENORTH STEEL. DUPLICATION WITHOUT WRITTEN PERMISSIONS IS STRICTLY PROHIBITED.

