



CORRUGATED STEEL PIPE

REFERENCE GUIDE



TrueNorthSteel.com

Table of Contents

SPECIFICATION GUIDE	2
STRUCTURAL DESIGN	4
HANDLING WEIGHTS	5
HEIGHT OF COVER TABLES	6
CONNECTION GUIDE	10
CSP END FINISHES	12
TRUENORTH STEEL LOCATIONS	15



Corrugated Steel Pipe Design Guide

TrueNorth Steel® manufactures and supplies a wide range of drainage pipe materials to service virtually any application, including culverts, storm drains, irrigation, agricultural drainage, conduits, small bridges and underground storm water detention systems. We have extensive experience and expertise in assisting engineers, project owners, and contractors with the design and installation of these systems and the selection and specification of the proper materials to meet the project requirements.

We manufacture and supply corrugated steel pipe from 6" diameter through 144" in round and pipe arch shapes using galvanized steel, aluminized steel, and polymer coated galvanized steel. *(192" diameter corrugated steel pipe is available from some locations. Please inquire.)*

We also manufacture Spiral Ribbed corrugated steel pipe featuring a Manning's "n" of .012 which is widely utilized for storm drains where a smooth interior pipe is a necessity. Slotted drain for curb drains and sheet flow drainage is available in a wide range of configurations. If it conveys water, TrueNorth Steel has the expertise.

Our manufacturing facilities and stocking locations in Missoula, MT; Billings, MT; Huron, SD; Fargo, ND; Mandan, ND; and Blaine, MN can manufacture a full range of wyes, tees, elbows, risers, and manholes.

Additionally, TrueNorth Steel specializes in prefabricated headwall assemblies for corrugated steel pipe which dramatically speeds up construction, reduces cost and protects culverts from erosion and scour forces.

For those projects requiring larger pipe sizes or specialized shapes such as box culverts, refer to our **TruePlate™ Structural Plate** guideline.

It is our mission to service our customers in a timely manner with high quality materials from all of our sites. We stock a wide range of sizes, corrugations, coatings and lengths and take pride in responding quickly to emergencies unplanned needs. Our in-house logistics group delivers corrugated steel pipe to your location utilizing our fleet of trucks and trailers.

Our experienced local representatives are available to provide pricing and availability, technical guidance, and field installation support. Materials are also supplied through an extensive network of distributor partners across WI, MN, SD, NE, CO, ND, WY, ID, and MT.

This corrugated steel pipe reference guide provides extensive information to assist with the design and selection of corrugated steel pipe materials but additional information is available through our website at truenorthsteel.com where you can find the contact information for our local representatives.

TrueNorth Steel is a third-generation, family-owned company founded in Fargo, ND in 1945. Meeting customer needs through local manufacturing and dependable solutions has fueled our growth. When you partner with TrueNorth Steel, you support your local economy and receive the very best in service, quality, and value.

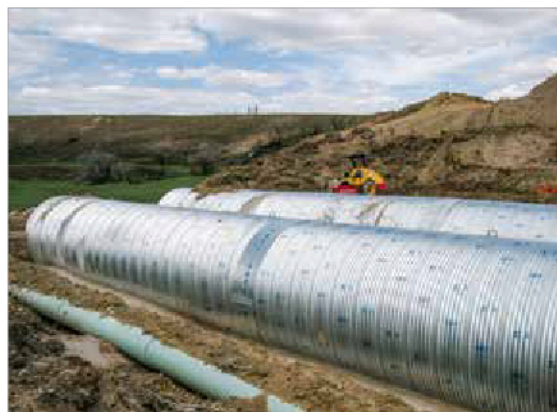
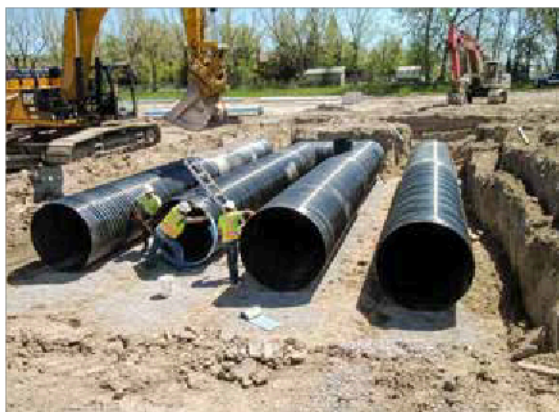

Corrugations

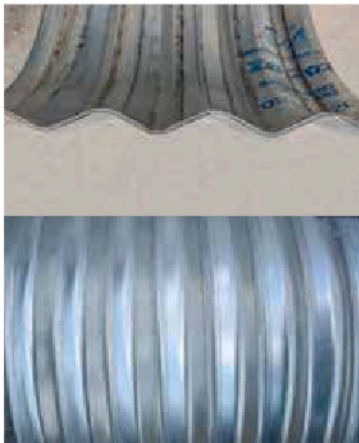
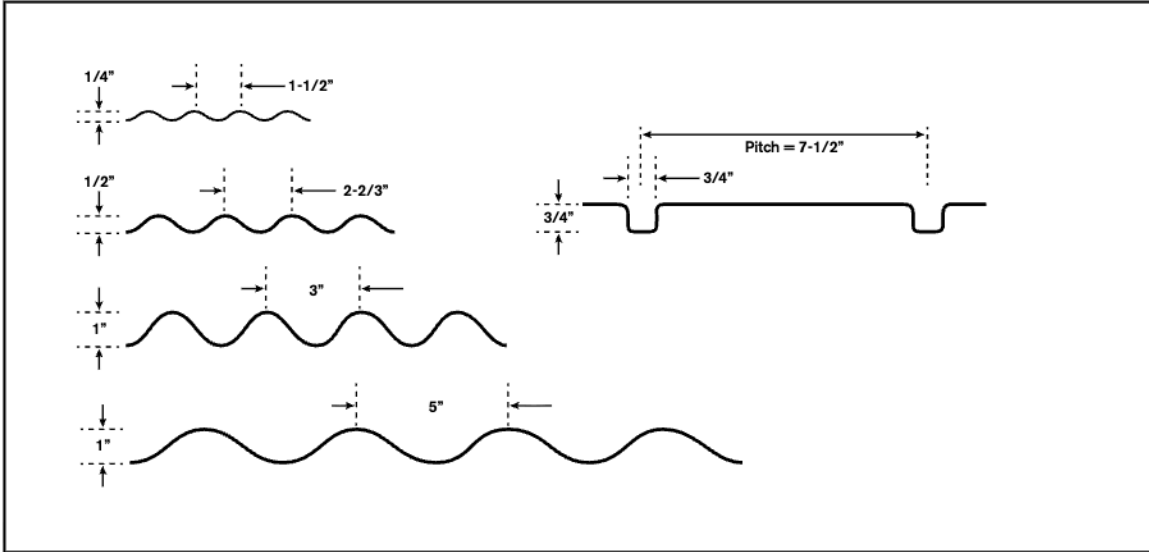

2-2/3" x 1/2" Corrugation

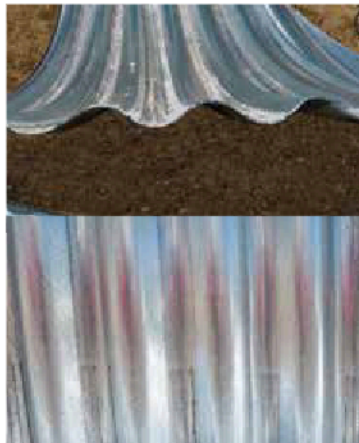

5" x 1" Corrugation

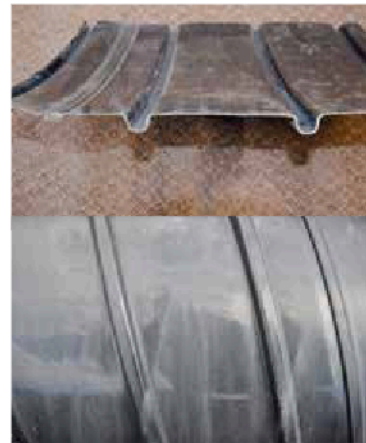

7-1/2" x 3/4" Spiral Rib Corrugation

CONVERSION OF NOMINAL GAGE TO THICKNESS							
Gage No. (in.)	22	20	18	16	14	10	10
Uncoated Thickness	0.0299	0.0359	0.0478	0.0598	0.0747	0.1046	0.1345
Galvanized Thickness*	0.034	0.040	0.52	0.064	0.079	0.109	0.138
Galvanized Structural Plate Thickness						0.111	0.140
Gage No. (in.)	8	-	-	-	-	-	-
Uncoated Thickness	0.164	-	-	-	-	-	-
Galvanized Thickness*	0.168	-	-	-	-	-	-
Galvanized Structural Plate Thickness	0.170	-	-	-	-	-	-

*Also referred to as specified thickness for corrugated steel pipe products

Corrugated Steel Pipe – Galvanized and Aluminized

APPROXIMATE HANDLING WEIGHTS BY GAGE (LBS/FT)							
Corrugation	Dia. (in)	18 Gage	16 Gage	14 Gage	12 Gage	10 Gage	8 Gage
1-1/2" x 1/4"	6	4	5				
	8	5	6				
	10	7	8				
2-2/3" x 1/2"	12	8	10	12	16		
	15	10	12	15	20		
	18	12	15	18	24		
	21	14	17	21	29		
	24	15	19	24	33	41	
	27		22	27	37	47	
	30		24	30	41	52	
	36		29	36	49	62	75
	42		34	42	57	72	87
	48		38	48	65	82	100
	54			54	73	92	112
	60				81	103	124
	66				89	113	137
	72					123	149
78						161	
5" x 1" 3" x 1" values found by increasing 5" x 1" weights by 12%.	48		39	48	65	83	100
	54		44	54	73	93	114
	60		48	59	81	104	126
	66		53	65	89	114	138
	72		58	71	97	123	150
	78		62	77	105	134	163
	84		68	83	113	144	175
	90		72	88	121	154	187
	96		77	94	129	165	201
	102		82	100	136	174	212
	108			106	145	186	225
	114			112	153	195	238
	120				161	206	250
	126				172	217	263
132				180	228	276	
138				187	238	289	
144					248	303	
3/4" x 3/4" x 7-1/2"	15		13	16			
	18		15	19	26		
	21		18	22	30		
	24		20	25	34		
	27		22	27	38		
	30		25	30	42		
	33		27	33	46		
	36		30	36	50		
	42		34	42	58		
	48		39	48	66	83	
	54		44	54	74	94	
	60		49	60	82	104	
	66			66	90	114	
	72			72	99	124	
	78			78	107	135	
	84				115	145	
	90				123	155	
	96				131	165	
102				139	176		
108					186		
114					196		
120					206		

Corrugated Steel Pipe Backfill Heights

ROUND PIPE						
2-2/3" x 1/2" Corrugations						
Pipe Size (inches)	Minimum cover (inches)	Steel Thickness (Gage)				
		16	14	12	10	8
		Galvanized Thickness (inches)				
		0.064	0.079	0.109	0.138	0.168
Corrugated Steel Pipe Backfill Heights (feet)						
12	12	219	273	–	–	–
15	12	183	228	255	–	–
18	12	146	182	191	–	–
24	12	109	137	191	–	–
30	12	87	108	153	–	–
36	12	73	91	127	164	–
42	12	62	78	109	141	172
48	12	55	68	96	123	150
54	12	–	61	85	109	134
60	12	–	–	76	98	120
66	12	–	–	–	89	109
72	12	–	–	–	82	100
78	12	–	–	–	–	89
84	12	–	–	–	–	77

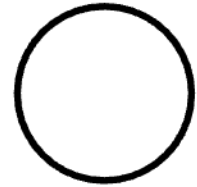

ROUND PIPE						
3" x 1" Corrugations						
Pipe Size (inches)	Minimum cover (inches)	Steel Thickness (Gage)				
		16	14	12	10	8
		Galvanized Thickness (inches)				
		0.064	0.079	0.109	0.138	0.168
Corrugated Steel Pipe Backfill Heights (feet)						
48	12	63	78	110	142	173
54	12	56	70	98	126	154
60	12	50	63	88	113	139
66	12	46	57	80	103	126
72	12	42	52	73	94	116
78	12	39	48	68	87	107
84	12	36	45	63	81	99
90	12	33	42	59	76	92
96	12	–	39	55	71	87
102	18	–	37	52	67	82
108	18	–	–	49	63	77
114	18	–	–	46	60	73
120	18	–	–	44	57	69

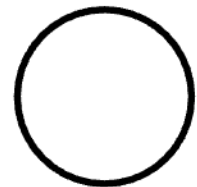

Tables are based on the following ASTM/AASHTO embankment criteria: pipe type (helical or annular, riveted or spot-welded); LRFD design method; fill density of 120 pcf (prism above pipe); minimum fill height of span/8, but not less than 12 inches; minimum cover for unpaved roadways measured from the top of gravel surfacing; and minimum cover for paved roadways measured to the top of the base for asphalt surfaces and to the top of the pavement for concrete surfaces.

Corrugated Steel Pipe Backfill Heights

ROUND PIPE						
5" x 1" Corrugations						
Pipe Size (inches)	Minimum cover (inches)	Steel Thickness (Gage)				
		16	14	12	10	8
		Galvanized Thickness (inches)				
		0.064	0.079	0.109	0.138	0.168
Corrugated Steel Pipe Backfill Heights (feet)						
48	12	56	70	98	126	154
54	12	50	62	87	112	137
60	12	45	56	78	101	123
66	12	41	51	71	92	112
72	12	37	47	65	84	103
78	12	34	43	60	78	95
84	12	32	40	56	72	88
90	12	30	37	52	67	82
96	12	-	35	49	63	77
102	18	-	33	46	59	73
108	18	-	-	44	56	69
114	18	-	-	41	53	65
120	18	-	-	39	50	62

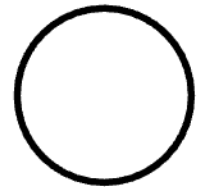

ROUND PIPE						
3/4" x 3/4" Rib at 7-1/2"						
Pipe Size (inches)	Minimum cover (inches)	Steel Thickness (Gage)				
		16	14	12	10	
		Galvanized Thickness (inches)				
		0.064	0.079	0.109	0.138	
Corrugated Steel Pipe Backfill Heights (feet)						
15	12	130	182	302	-	-
18	12	108	151	252	-	-
24	12	72	100	167	-	-
30	12	57	80	134	-	-
36	12	48	67	111	-	-
42	12	41	57	95	-	-
48	12	36	50	83	-	-
54	18	-	45	74	-	-
60	18	-	40	67	97	-
66	18	-	-	61	88	-
72	18	-	-	56	81	-
78	24	-	-	51	75	-

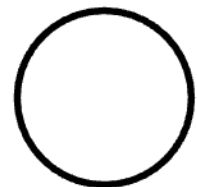

Tables are based on the following ASTM/AASHTO embankment criteria: pipe type (helical or annular, riveted or spot-welded); LRFD design method; fill density of 120 pcf (prism above pipe); minimum fill height of span/8, but not less than 12 inches; minimum cover for unpaved roadways measured from the top of gravel surfacing; and minimum cover for paved roadways measured to the top of the base for asphalt surfaces and to the top of the pavement for concrete surfaces.

Corrugated Steel Pipe Backfill Heights

ARCH PIPE								
2-2/3" x 1/2" Corrugations								
Equivalent Pipe Diameter	Span	Rise	Minimum cover (inches)	Steel Thickness (Gage)				
				16	14	12	10	8
				Galvanized Thickness (inches)				
				0.064	0.079	0.109	0.138	0.168
Inches				Corrugated Steel Pipe Backfill Heights (feet)				
15	17	13	12	14	-	-	-	-
18	21	15	12	13	-	-	-	-
21	24	18	12	14	-	-	-	-
24	28	20	12	13	-	-	-	-
30	35	24	12	13	-	-	-	-
36	42	29	12	13	-	-	-	-
42	49	33	12	-	13	-	-	-
48	57	38	12	-	-	13	-	-
54	64	43	12	-	-	13	-	-
60	71	47	12	-	-	-	13	-
66	77	52	12	-	-	-	-	13
72	83	57	12	-	-	-	-	13



ARCH PIPE								
3" x 1" Corrugations								
Equivalent Pipe Diameter	Span	Rise	Minimum cover (inches)	Steel Thickness (Gage)				
				14	12	10	8	
				Galvanized Thickness (inches)				
				0.079	0.109	0.138	0.168	
Inches				Corrugated Steel Pipe Backfill Heights (feet)				
48	53	41	12	21	-	-	-	-
54	60	46	15	21	-	-	-	-
60	66	51	15	21	-	-	-	-
66	73	55	18	21	-	-	-	-
72	81	59	18	18	-	-	-	-
78	87	63	18	17	-	-	-	-
84	95	67	18	17	-	-	-	-
90	103	71	18	-	17	-	-	-
96	112	75	21	-	17	-	-	-
102	117	79	21	-	17	-	-	-
108	128	83	24	-	-	16	-	-
114	137	87	24	-	-	16	-	-
120	142	91	24	-	-	-	-	16



Tables are based on the following ASTM/AASHTO embankment criteria: pipe type (helical or annular, riveted or spot-welded); LRFD design method; fill density of 120 pcf (prism above pipe); minimum fill height of span/8, but not less than 12 inches; minimum cover for unpaved roadways measured from the top of gravel surfacing; and minimum cover for paved roadways measured to the top of the base for asphalt surfaces and to the top of the pavement for concrete surfaces.

Corrugated Steel Pipe Backfill Heights

ARCH PIPE							
5" x 1" Corrugations							
Equivalent Pipe Diameter	Span	Rise	Minimum cover (inches)	Steel Thickness (Gage)			
				14	12	10	8
				Galvanized Thickness (inches)			
				0.079	0.109	0.138	0.168
Inches			Corrugated Steel Pipe Backfill Heights (feet)				
48	53	41	12	-	21	-	-
54	60	46	15	-	21	-	-
60	66	51	15	-	21	-	-
66	73	55	18	-	21	-	-
72	81	59	18	-	18	-	-
78	87	63	18	-	17	-	-
84	95	67	18	-	17	-	-
90	103	71	18	-	17	-	-
96	112	75	21	-	17	-	-
102	117	79	21	-	17	-	-
108	128	83	24	-	-	16	-
114	137	87	24	-	-	16	-
120	142	91	24	-	-	-	16



ARCH PIPE							
3/4" x 3/4" Rib @ 7-1/2"							
Equivalent Pipe Diameter	Span	Rise	Minimum cover (inches)	Steel Thickness (Gage)			
				16	14	12	10
				Galvanized Thickness (inches)			
				0.064	0.079	0.109	0.138
Inches			Corrugated Steel Pipe Backfill Heights (feet)				
18	20	16	12	16	-	-	-
21	23	19	12	15	-	-	-
24	27	21	12	14	-	-	-
30	33	26	12	14	-	-	-
36	40	31	12	14	-	-	-
42	46	36	12	14	-	-	-
48	53	41	18	-	14	-	-
54	60	46	18	-	21	-	-
60	66	51	18	-	-	21	-
66	73	55	18	-	-	21	-
72	81	59	18	-	-	-	18
78	87	63	18	-	-	-	17
84	95	67	18	-	-	-	17



Tables are based on the following ASTM/AASHTO embankment criteria: pipe type (helical or annular, riveted or spot-welded); LRFD design method; fill density of 120 pcf (prism above pipe); minimum fill height of span/8, but not less than 12 inches; minimum cover for unpaved roadways measured from the top of gravel surfacing; and minimum cover for paved roadways measured to the top of the base for asphalt surfaces and to the top of the pavement for concrete surfaces.

CSP Connection Guide

Corrugated steel pipe connections (connecting bands) are supplied to meet the specific needs of each project. Most culverts and storm drains require a connection that provides a soil tight mechanical connection that joins the pipe ends. These connections, when properly installed, provide resistance to lateral displacement and in-line (or pull-apart) resistance unlike concrete pipe and plastic pipe connections.

Typical connecting band widths are either 7", 12" or 24" wide and may be supplied with neoprene o-ring or neoprene flat sleeve gaskets. Specialized connections for severe applications include high-strength threaded rods and lugs to provide an extra measure of resistance to displacement.

For complete guidance refer to either section 9 of ASTM A760 or the National Corrugated Steel Pipe Association Corrugated Steel Pipe Design Manual (Refer to page 98). TrueNorth Steel is available to provide support with selecting the appropriate connecting band system to meet your specific needs.

TrueNorth Steel Pipe Joining Systems

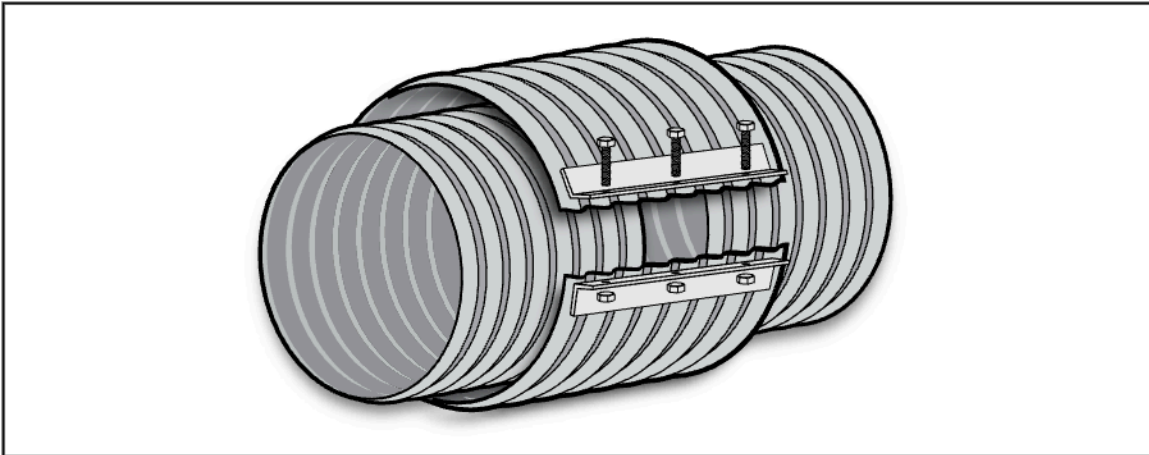

TrueNorth Steel standard pipe joining systems involve wrap-around style metal bands with connecting hardware. Connecting bands are offered in a one-piece or two-piece assembly. Two-piece are more typical with large diameter CSP.

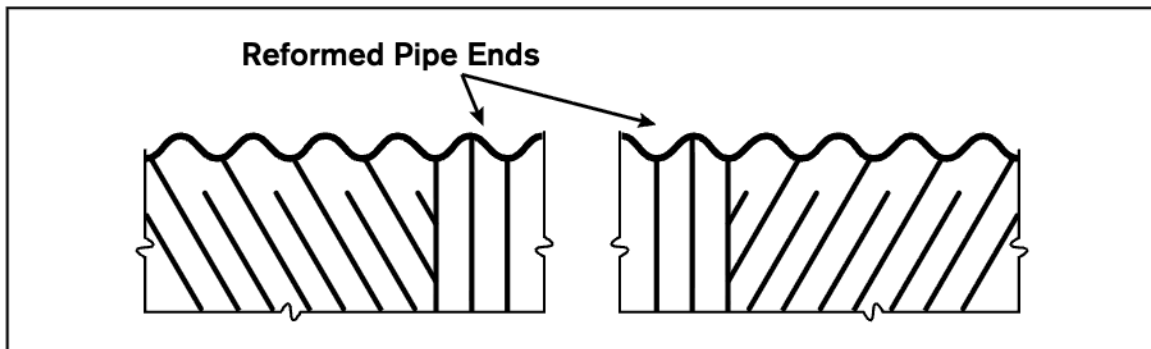

If pipe corrugations are helically formed, the pipe ends are reformed into annular corrugations to engage certain coupling bands. Regardless of the actual pipe corrugation used the annular corrugated ends are reformed with a 2-2/3" x 1/2" corrugation. *If requested, pipe may be supplied with un-reformed ends.*

Corrugated Bands

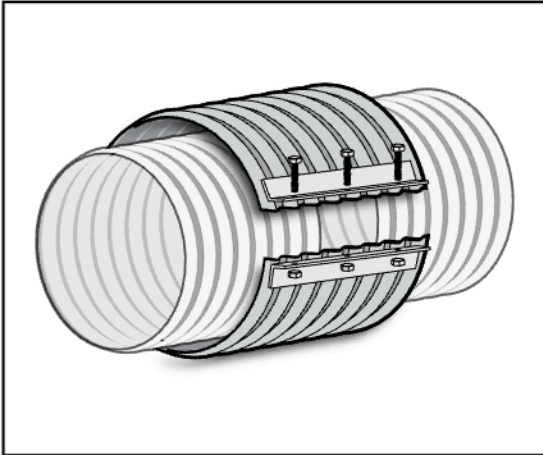

Annular corrugated bands are available in nominal widths of 7", 12" and 24".

Dimple Bands

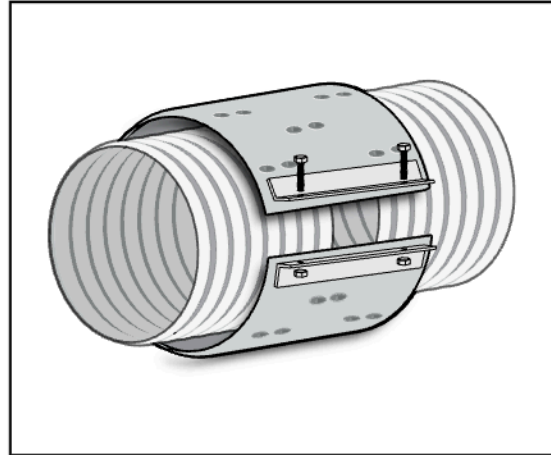

Dimple bands are bands with dimple projections in annular rows. As with flat bands they may be used on pipe with helical ends (i.e., ends that have not been reformed with annular corrugations). Dimple bands are available for 12"-96" CSP. Dimple bands come in widths of 10" or 16".

Flat Bands

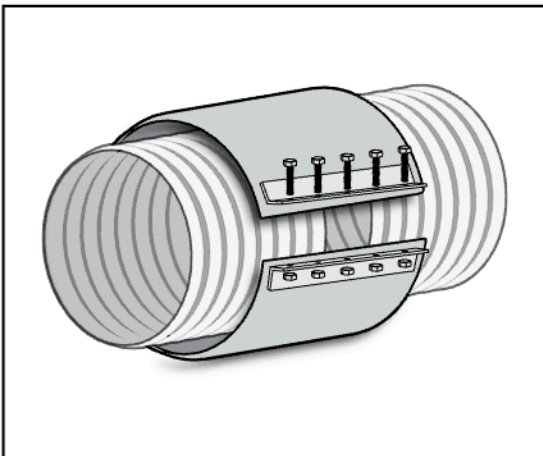

Bands with no corrugations or projections are available in nominal varying widths.

Sleeve Gaskets

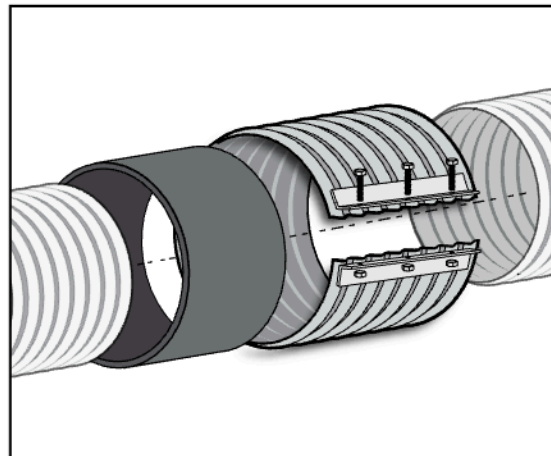

Gaskets are typically made of a 3/8" thick neoprene material to enhance the leak resistance quality of the joint. The sleeve gaskets slide over the pipe ends and underlay the connecting band available in 12" or 24" widths. O-ring gaskets are also available.

End Treatment for CSP

Purposes

The principal purpose of pipe end treatment on corrugated steel pipe culverts is to reduce turbulence and scour at the inlet and outlet, undermining at the outlet, and to increase flow capacity. Other functions may be to retain the fill slope, discourage burrowing rodents, or improve safety. For additional information, see NCSPA Corrugated Steel Pipe Design Manual - chapters 4 and 5, on Hydraulic Design, and Chapters 7 and 8, Structural Design and Special Design.

Types of End Treatment

Types of steel end treatment include: (1) Flared end sections, (2) safety slope flared end sections, (3) pipe cut-end skews and bevels, (4) steel sheeting to serve as a low headwall and cutoff wall, and (5) prefabricated, corrugated steel headwalls, (6) cut back style safety aprons.

End Sections

Steel end sections are fabricated for assembly in the field by attachment to corrugated steel culverts from 6" to 96" diameter or pipe arches from 17" x 13" to 112" x 75". Dimensions and other data are given in the charts on the following pages or Figures 2.29 and 2.30 in the NCSPA Corrugated Steel Pipe Design Manual.

These end sections are listed in standard specifications of state highway departments, county road departments, railroads and other specifying entities. They meet the requirements for efficient and attractive end finish on culverts, conduits, spillways and sewer outfalls.

End sections attach to the culvert ends by bolted connections of various designs and can be completely salvaged and reused if lengthening or relocation is necessary.



Flared End Section



Safety Slope Flared End Section

Flared End Sections

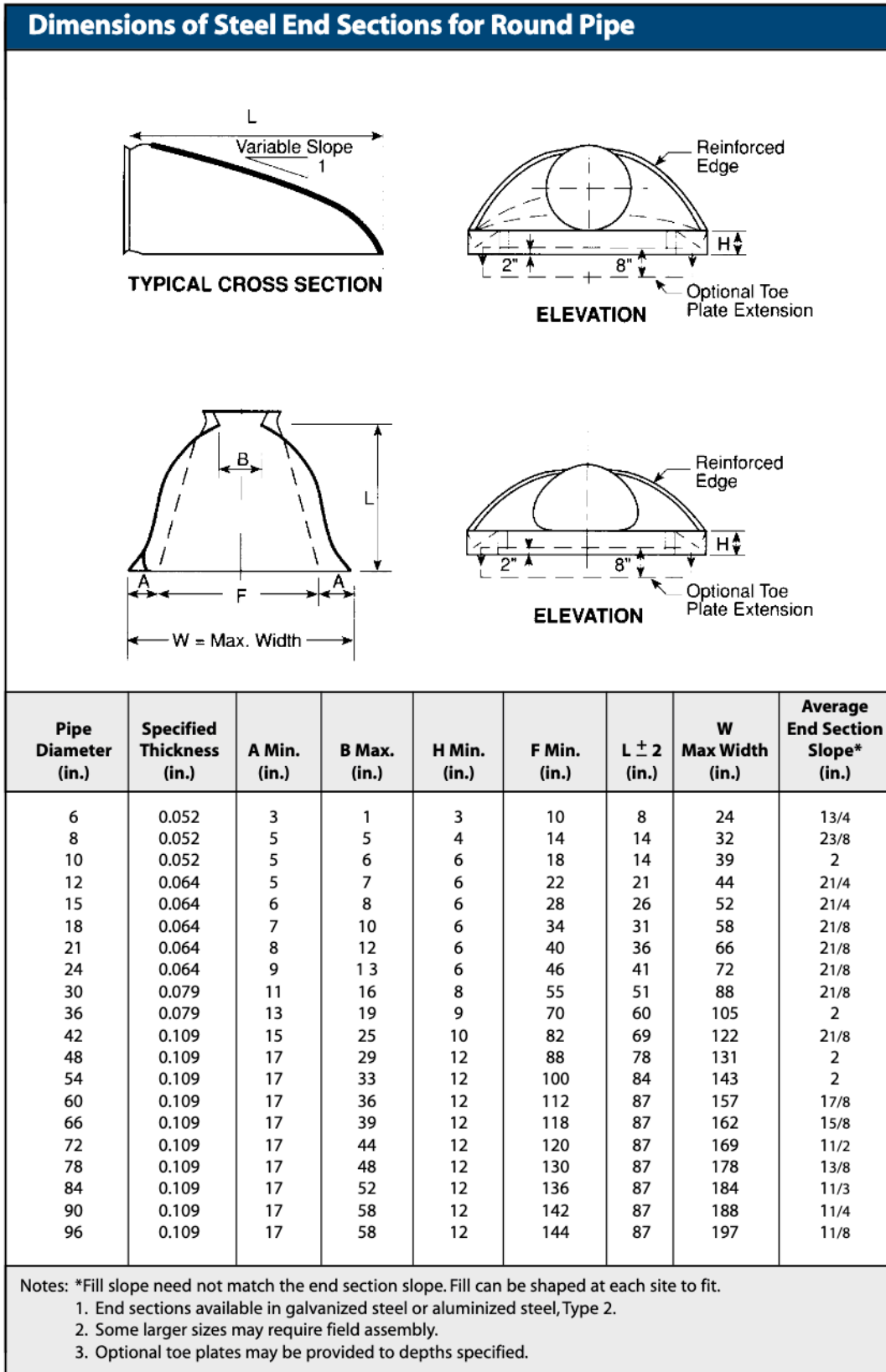

Dimensions of Steel End Sections for Pipe Arch 2-2/3 x 1/2 Inches Corrugations

Span x Rise (in.)	Equip/ Round (in.)	Specified Thickness (in.)	A Min. (in.)	B Max. (in.)	H Min. (in.)	F Min. (in.)	L ± 2 (in.)	W Max Width (in.)	Approx. Average End Section Slope* (in.)
17 x 13	15	0.064	5	9	6	28	20	52	21/8
21 x 15	18	0.064	6	11	6	34	24	58	2
24 x 18	21	0.064	7	12	6	40	28	63	21/8
28 x 20	24	0.064	7	16	6	46	32	70	2
35 x 24	30	0.079	9	16	6	58	39	85	17/8
42 x 29	36	0.079	11	18	7	73	46	104	17/8
49 x 33	42	0.109	12	21	9	82	53	117	13/4
57 x 38	48	0.109	16	26	12	88	62	132	17/8
64 x 43	54	0.109	17	30	12	100	69	144	17/8
71 x 47	60	0.109	17	36	12	112	77	156	17/8
77 x 52	66	0.109	17	36	12	124	77	167	15/8
83 x 57	72	0.109	17	44	12	130	77	177	11/2

Notes: *Fill slope need not match the end section slope. Fill can be shaped at each site to fit.

1. End sections available in galvanized steel or aluminized steel, Type 2.
2. Some larger sizes may require field assembly.
3. Optional toe plates may be provided to depths specified.

Excerpted from National Corrugated Steel Pipe Association

Dimensions of Steel End Sections For Pipe Arch 3 x 1 Inches and 5 x 1 Inches Corrugations

Span x Rise (in.)	Equip/ Round (in.)	Specified Thickness (in.)	A Min. (in.)	B Max. (in.)	H Min. (in.)	F Min. (in.)	L ± 2 (in.)	W Max Width (in.)	Approx. Average End Section Slope* (in.)
53 x 41	48	0.109	17	26	12	88	63	130	13/4
60 x 46	54	0.109	17	36	12	100	70	142	17/8
66 x 51	60	0.109	17	36	12	112	77	156	13/4
73 x 55	66	0.109	17	36	12	124	77	168	11/2
81 x 59	72	0.109	17	44	12	136	77	179	15/8
87 x 63	78	0.109	17	44	12	136	77	186	11/2
95 x 67	84	0.109	17	44	12	160	87	210	11/2
103 x 71	90	0.109	17	44	12	172	87	222	11/3
112 x 75	96	0.109	17	44	12	172	87	226	11/4
117 x 79	102	0.109	20	62	12	154	87	234	1 1/2
128 x 83	108	0.109	20	68	12	176	87	256	1 1/2
137 x 87	114	0.109	20	73	12	194	100	274	1 1/2
142 x 91	120	0.109	20	75	12	204	98	284	1 1/2

Notes: *Fill slope need not match the end section slope. Fill can be shaped at each site to fit.

1. End sections available in galvanized steel or aluminized steel, Type 2.
2. Some larger sizes may require field assembly.
3. Optional toe plates may be provided to depths specified.

Excerpted from National Corrugated Steel Pipe Association

CSP Beveled and Skewed End Treatment

TrueNorth Steel beveled end sections are a practical and visually attractive way to complete an installation that incorporates a slope at either end of a culvert. Beveled ends at the pipe inlet limit scour and beveled ends also limit undermining at the outlet end. When the ends of corrugated pipe are beveled or skewed to match the embankment slope they will deliver improved hydraulic characteristics. Additional benefits of beveled and skewed ends include retaining the fill slope, discouraging burrowing rodents and improving roadside safety.

Typical bevel angles are 3:1 and 4:1 but other angles are available as are skew cut ends to match culverts skewed to the roadway centerline. A combination of bevel and skew is also available.

Beveled ends can be a full bevel cut but TrueNorth Steel recommends the use of "step beveled" ends which incorporate a vertical cut at the top of the bevel and a similar vertical cut at the tip of the beveled end section. The vertical "step" cuts at the top of the bevel increase the stiffness of the bevel and the vertical "step" at the bottom of the bevel eliminates the possibility of the bottom being damaged by hydraulic uplift forces.

Your TrueNorth Steel representative is available to advise you on skew and bevel cut ends on CSP.



1½:1 Bevel Top and Bottom Step



3:1 Bevel Top and Bottom Step

For more information call 1-866-982-9511 or one of our locations below:

West Fargo, ND	420 Main Avenue E - Bldg 520	West Fargo, ND 58078	701.282.0910
Mandan, ND	2522 Memorial Highway	Mandan, ND 58554	701.663.0321
Huron, SD	220 4th Street NW	Huron, SD 57350	605.352.8643
Blaine, MN	3575 85th Avenue NE	Shoreview, MN 55126	763.780.1760
Billings, MT	1501 South 30th Street W	Billings, MT 59102	406.656.2253
Missoula, MT	6400 US Highway 10 W, Suite 1	Missoula, MT 59808	406.542.0345



STRENGTH BELOW THE SURFACE



**VIEW THE COMPLETE
REFERENCE GUIDE**

DRAINAGE@TRUENORTHSTEEL.COM | [701.282.0910](tel:701.282.0910) | TRUENORTHSTEEL.COM